



FORMED OR FORGED FITTINGS

The schematic drawings in adjoining columns represent basic rod or wire forms and steel eye bolt forgings. Space does not permit the design illustrations of all parts that we are capable of manufacturing.

A review of complete catalog literature will indicate an extensive listing of standard stock sizes of round bend U-bolts, turned or formed eye bolts and forged steel eye bolts in several patterns.

When it is not feasible to utilize a standard product, we are prepared and equipped to manufacture requirements to specification. Inquiries are solicited.

Variation in quantity: on special items we reserve the right to a maximum 10% variation for allowances in manufacture.

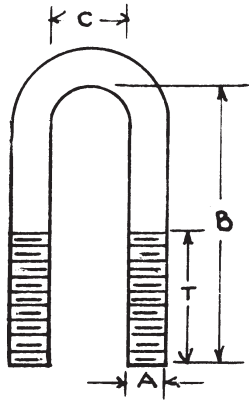

Figure No. 1

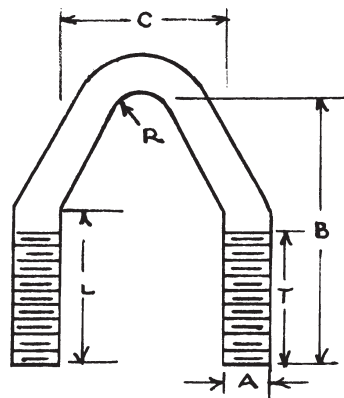

Figure No. 2

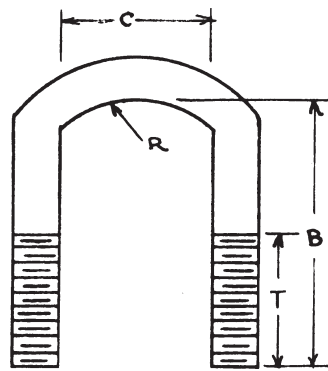

Figure No. 3

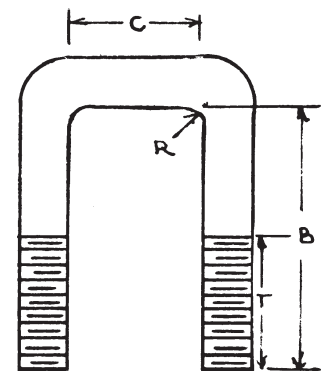

Figure No. 4

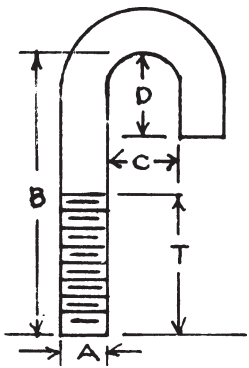

Figure No. 5

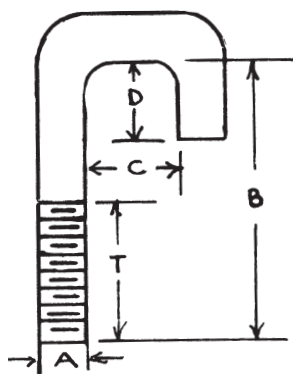

Figure No. 6

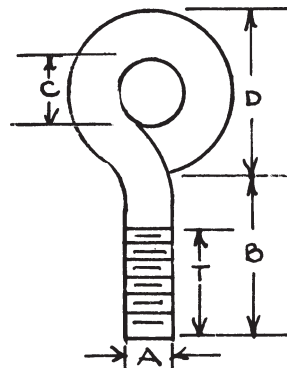

Figure No. 7

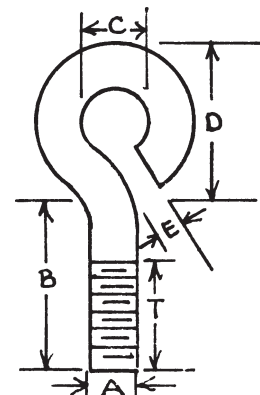

Figure No. 8

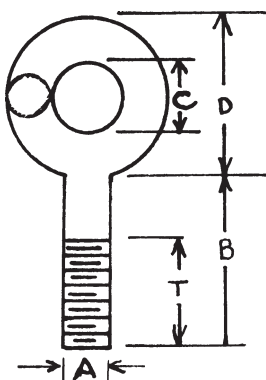

Figure No. 9

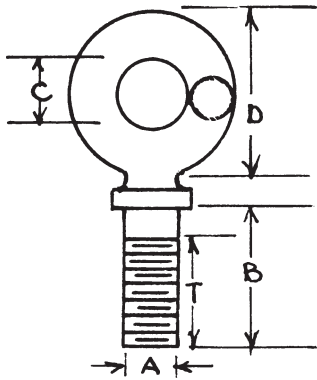

Figure No. 10

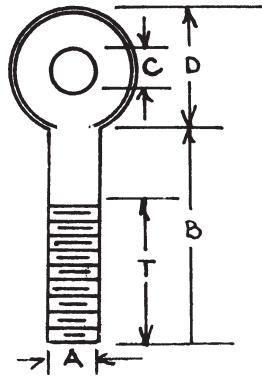
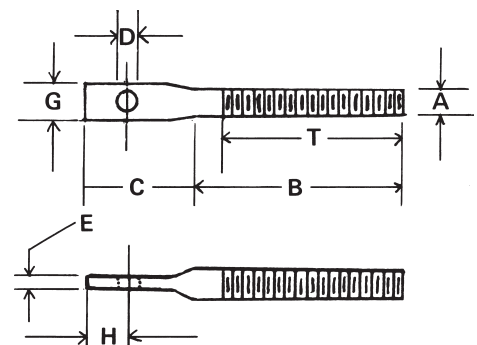

Figure No. 11



Spade Bolt